

广州安的电子技术有限公司
SafTTY Electronic Technology Co., Limited

ST01 U6 系列热保护器技术规格书

Technical Specifications for ST01 U6 Series Thermal
Protector



编制 Draw up: 叶东

审核 Examine: 吴如洋

批准 Approved: _____

发布日期 Issue Date: 2025.07.17

ST01 U6 系列热保护器技术规格书

Technical Specifications for ST01 U6 Series Thermal Protector

1. 产品用途 Product application

ST01 U6系列热保护器具有体积小、电流热效应小、控温准确、感温灵敏、抗压强度高等特点，广泛适用于电动机、水泵，变压器、线圈、电子产品、传感器的过热保护。ST01 U6 series thermal protector has the following features: miniature size, The thermal effect of current is slight, accurate temperature response, temperature sensitive, compact and pressure stable, etc. It is widely used in electric motors, pumps, transformers, coils, electronics and sensors for thermal overheat protection.

2. 外形和结构: Shape and structure

①动作温度范围 Operating Temp. Range from 60°C-180°C

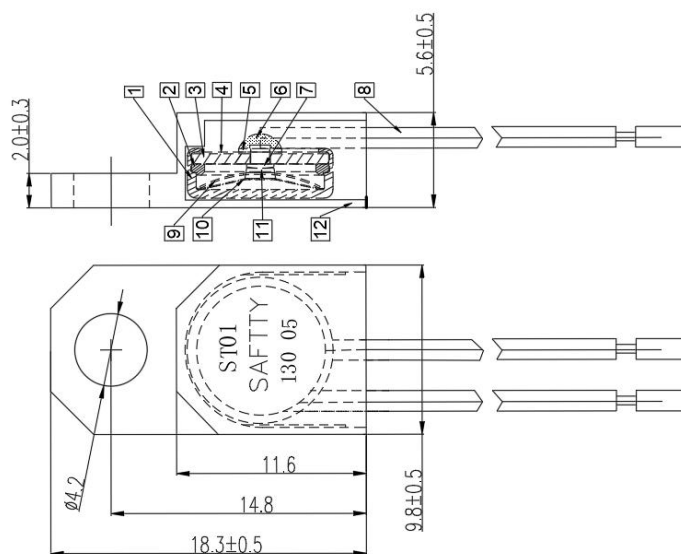

序号 No.	零件名称 Part name	序号 No.	零件名称 Part name	序号 No.	零件名称 Part name
1	外壳 Case	5	垫片 shim	9	簧片 Spring
2	环 Ring	6	环氧树脂 Epoxy resin	10	双金属片 Bimetal-disc
3	盖板 Cover plate	7	静触点 Stationary contact	11	动触点 Movable contact
4	日东纸 Insulation paper	8	引线 Lead wire	12	耐高温塑料绝缘外壳 High temperature resistant plastic insulated housing

3. 性能 (性能数据均为内部实验室测试, 供客户参考。客户应根据自己的标准确认是否适用。我们保留在进一步发展过程中做出改变的权利。)

Capabilities(The performance data are all internal laboratory tests for customer reference. Customers should confirm whether it is applicable based on their own standards.We reserve the right to make changes during further development.)

3.1 电气参数

额定交流电压 Rated AC voltage: 250V;

额定直流电压 Rated DC voltage: 24V;

最大承受电压 Maximum withstand voltage: AC500V DC28V;

额定电流/寿命 Rated current/lifetime (COS Φ=1.0) ;

AC 2.5A-10000cycles;

AC 6.3A-3000cycles;

AC 7.5A-300cycles;

3.2 动作特性: Performance

3.2.1 额定断开温度 60°C~180°C (详见附表)。

Rated open temperature: 60°C~180°C(details as per attached list)

3.2.2 复位温度 (详见附表)。

Reset temperature: (details as per attached list)

3.3 电气强度 Electric strength:

测试仪器为耐压测试仪 the test instrument is high voltage tester.

a. 产品在断开时的引线之间应能承受 AC500V, 历时 1min 而无击穿闪络现象;

When the product is in the breaking state, the lead wires should be able to withstand AC500V lasting for 1min without breakdown or flash-over;

b. 产品引线与绝缘外壳之间能承受 AC1500V, 历时 1min 而无击穿闪络现象。

The part between the lead wires and the case should be able to withstand AC1500V lasting for 1min without breakdown or flash-over;

3.4 绝缘电阻 Insulation resistance:

在正常条件下, 引线与绝缘外壳之间的绝缘电阻在100MΩ以上。(所用表计为DC500V 兆欧表) Under normal conditions, the insulation resistance between leads (terminal) and case should be more than 100MΩ measured by ohmmeter of DC500V.

3.5 接触电阻 Contact resistance

标准引线长度 55mm 产品的接触电阻应不大于 50mΩ。

The contact resistance of standard lead wire length 55mm products should be lower than 50mΩ.

3.6 抗拉力试验 Tensile resistance test

产品的引线端应能承受大于或等于 30N 静拉力并保持 1 分钟，导线不断裂或松动。

Terminal & leads should endure more than 30N axes direction pull lasting for 1 minute without break or looseness.

3.7 耐高温试验 High temperature test

产品置于高于额定动作温度 30°C 的空气环境中保持 16h，取出放置 2 小时后，检测其温度变化不超过初始值的 ±5°C 或 ±5%，取最大值。

Keep the thermal protector in an incubator which temp. is 30°C higher than its rated switching temperature for sixteen hours, and test it two hours later after taking out from the incubator, while the temperature change does not exceed the initial value of ± 5°C or ±5%, returns the maximum value.

3.8 耐低温试验 Low temperature resistance test

产品置于 -40°C 空气环境中保持 2h，取出放置 2 小时后，检测其温度变化不超过初始值的 ±5°C 或 ±5%，取最大值。

Keep the thermal protector in a -40°C incubator for two hours, and test it two hours later after taking out from the incubator, while the temperature change does not exceed the initial value of ±5°C or ±5%, returns the maximum value.

3.9 抗振试验 Anti-Vibration test:

热保护器应能承受振幅 1.5mm，频率变化 10~55Hz，扫描变化周期 3~5 次/min，振动方向 X、Y、Z，每个方向各连续振动 2h，检测其温度变化不超过初始值的 ±5°C 或 ±5%，取最大值。Thermal protector should be able to withstand the amplitude 1.5mm, frequency 10- 55Hz, scanning change cycles of 3-5 times /min. The vibration direction X, Y, Z and each direction vibrates on a continuous basis for 2 hours while the temperature change does not exceed the initial value of ±5°C or ±5%, returns the maximum value.

3.10 极限短路试验 Short-circuit limit test

产品在串接 RL1-15A 熔断器的电路中承受 200A 的极限短路电流时，应不引起包裹在保护器上的棉花燃烧。

When the thermal protector is in series connection with RL1-15A fuse to withstand short circuit current limit of 200A, it should not cause the cotton

burned which is wrapped on the thermal protector.

4 产品断开弹跳时间 Product disconnection bounce time

Bounce Time<1ms.

5 其他事项: Others

5.1 断开温度检测的升温速率应控制为 1°C/1min, 用指示灯显示通断状态, 允许通过产品的电流不超过 0.01A。

For action temperature testing, temperature rising rate should be controlled at 1°C/min and use indicator light to show the on/off state. The testing current should be no more than 0.01A.

5.2 使用过程中产品不能承受强烈冲击力及压迫力; 最大承受压力为 300N.

In your production, the thermal protectors could not withstand a big impact and stress. The maximum bearing pressure is 300N.

5.3 型号规格说明: Model Code System explanation

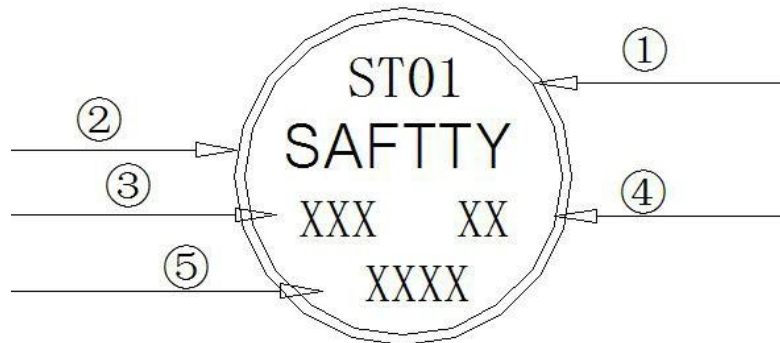

产品内部外壳打标 The mark of internal metal case

① ST01--产品型号 Model No.

如果产品型号在第一行, 字体颜色为黑色, 则表示产品为常闭产品。如果产品型号在第三行, 字体颜色为红色, 则表示产品为常开产品。If the product model is in the first line and the font color is black, it indicates a normally closed product. If the product model is in the third line and the font color is red, it indicates a normally open product.

② SAFTTY--安的公司标志 SAFTTY logo

③ XXX--产品动作温度 (060-180), 表示该产品在标识温度情况下动作 (单位: °C)

Product operating temperature (060-180), indicating that the product is operating at the identified temperature (unit: °C)

④ XX--产品动作温度精度, 05 --->±5°C 10 --->±10°C。

Product operating temperature tolerance, 05 --->±5°C; 10 --->±10°C.

⑤ XXXX--生产批次号，用来产品追溯。批次生成规则如下：

Production batch number for product traceability. The batch generation rules are as follows:

生产批次号
Production batch number

K	v	A	1				
				每周批次顺序号（以大写英文字母加1-9数字组成，数字与字母循环组合） Weekly batch sequence number (composed of uppercase English letters plus 1-9 numbers, numbers combined with letter loops)			
				周（用大写或小写或数字组成，详见以下周序号列表） Weeks (consisting of uppercase or lowercase or numbers, see the list of weekly serial numbers below)			
				年份（用大写英文字母表示，详见以下表） Year (expressed in capital letters, see table below)			
如：2024年48周第1批次产品应表示为：KvA1 For example, the first batch of products in the 48th week of 2018 should be expressed as: EvA1							
1. 年序号表如下 The chronological table is as follows:							
年份 YEAR	2024	2025	2026	2027	2028	2029	2030
标记 MARK	K	L	M	N	O	P	Q
2. 周序号表如下 The weekly sequence number table is as follows:							
周 WEEK	1(27)	2(28)	3(29)	4(30)	5(31)	6(32)	7(33)
标记 MARK	A(a)	B(b)	C(c)	D(d)	E(e)	F(f)	G(g)
周 WEEK	8(34)	9(35)	10(36)	11(37)	12(38)	13(39)	14(40)
标记 MARK	H(h)	I(i)	J(j)	K(k)	L(l)	M(m)	N(n)
周 WEEK	15(41)	16(42)	17(43)	18(44)	19(45)	20(46)	21(47)
标记 MARK	O(o)	P(p)	Q(q)	R(r)	S(s)	T(t)	U(u)
周 WEEK	22(48)	23(49)	24(50)	25(51)	26(52)	53	
标记 MARK	V(v)	W(w)	X(x)	Y(y)	Z(z)	9	

注：标准品引线为 UL3398/ UL10362, AWG22, 白色/黄色，引线长 55/55mm，半剥 6mm。

Standard lead wire is UL3398 or UL10362, AWG22, White or Yellow, 55mm and semi-stripped 6mm.

5.4 包装、储存、运输 Packing, storage and transportation

① 产品包装采用透明塑料自封袋，每个小包装袋含 100pcs，每个大包装包含 10 小包，发货均采用纸箱包装，尺寸为 32*26*25CM；如果总数量偏少，我司会采用其他规格纸箱。

Product packaging using transparent plastic self-sealing bags, each small packaging bag contains 100pcs, each large package contains 10 small packets, the

delivery is packed in cartons, the size is 32 * 26 * 25CM; if the total quantity is small, our company will use other specifications of cartons.

② 储存时放于湿度 40%~80%、温度-5~40°C环境中 12 个月无变化;

The product should be stored at the -5~40°C environment with the relative humidity of 40%~80% for 12 months without changes.

③ 直接运输或托运, 应轻拿轻放, 避免碰撞或受潮。

Direct transportation or shipment, it should be handled carefully and avoid collision or damp.

④ 如有防真空浸漆要求, 请在报价前向我司销售人员说明具体要求。

If you products need to suitable for vacuum impregnation process, please explain the specific requirements to our sales before quoting.

附表1: Attached list 1

序号 No.	动作温度°C Open temp.	复位温度°C Reset temp.	序号 No.	动作温度°C Open temp.	复位温度°C Reset temp.
1	60±5	35-53	14	125±5	95±15
2	65±5	36-57	15	130±5	100±15
3	70±5	36-57	16	135±5	105±15
4	75±5	38-63	17	140±5	110±15
5	80±5	53±15	18	145±5	115±15
6	85±5	57±15	19	150±5	120±15
7	90±5	60±15	20	155±5	125±15
8	95±5	65±15	21	160±5	130±15
9	100±5	70±15	22	165±5	135±15
10	105±5	75±15	23	170±5	140±15
11	110±5	80±15	24	175±5	145±15
12	115±5	85±15	25	180±5	150±15
13	120±5	90±15			

附表2: Attached list 2 (供参考)

序号No.	导线型号 Wire type	线号 AWG	线芯数量 Number of cores	导线外 (mm) Wire outer diameter	导线电阻值 Wire resistance value (mm/mΩ)
1	UL10362	22	19	1.35	0.055
2	UL10362	20	19	1.52	0.034
3	UL1332	18	1	1.72	0.029
4	UL1332	18	19	1.85	0.029
5	UL1332	20	19	1.65	0.034
6	UL1332	22	1	1.32	0.055
7	UL1332	22	19	1.45	0.055
8	UL1332	24	7	1.3	0.086
9	H05S-K	20	16	2.12	0.034
10	UL10086	18	19	1.75	0.034
11	UL3135	20	28	2.1	0.034
12	UL3135	22	19	1.88	0.055
13	UL3398	20	21	1.75	0.034
14	UL3398	22	17	1.6	0.055
15	UL3398	24	11	1.45	0.086
16	UL3266	18	16	1.96	0.029

注:

因保护器使用线规线长变化较多,规定保护器阻值的计算方式为:导线阻值+保护器咪头阻值*咪头数量(导线长度×对应导线电阻值+40毫欧*咪头数量)

Due to the difference in the wire gauge and line length of the protector, our company stipulates that the calculation method of the protector resistance value is:
 protector resistance = wire resistance value + protector head resistance value
 ×Number of protector heads(wire length× corresponding to the wire resistance value
 + 40 mΩ×Number of protector heads)